

Parrilla GMB 200

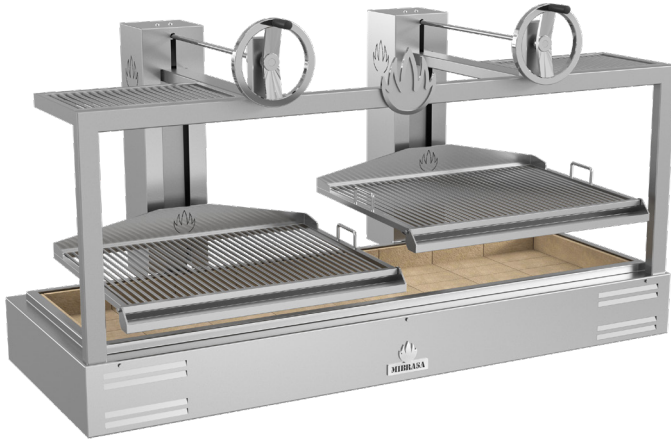

TECHNICAL INFORMATION

Fire up time ¹	30 min-average
Cooking temperature	250 °C
Total cooking surface area	2 x (635 x 890mm) = 1.13 m ²
Initial charcoal load ¹	20 kg
Grill height range	350 mm
Charcoal load duration ²	7 h
Equivalent power*	6 kW
Exhaust rate	5100 m ³ /h
Net weight ³	463 kg
Crated weight* ³	633 kg
Crated size (WxDxH)	1120 x 2200 x 1380

*Approximate data

1. Consult instruction manual

2. Will vary depending on quality of charcoal

3. Weight with accessories included

FEATURES

Precision and strength is key to the PARRILLA by MIBRASA®. Effortlessly regulate the height of your grill surface thanks to the carefully engineered pulley cable and counterweight system, keeping maintenance down to a minimum.

The system lets us sear, cook and rest our ingredients, to get the optimal result every time.

ERGONOMICALLY DESIGNED WITH MAXIMUM QUALITY AND SECURITY

With a sloping grill, the grease runs down the weld-free grill bars to prevent grease build-up. Grease drips down to the collector with an easy to remove mechanism ready to clean.

The base is lined with refractory bricks to ensure maximum heat efficiency and resistance to pure fire. And the built-in cooling system in outer case guarantees a maximum level of security.

Built using quality steels providing strength and durability; ergonomically designed for practicality and ease of use, each feature plays a crucial part in delivering the ultimate grilling machine for every chef.

INCLUDED ACCESSORIES

- 2 Rod grills [CPV200]
- 2 Mibrasa tongs [TG]
- Ember poker [PK]
- 2 Grill brushes [CEP]
- Ash shovel [PALA]
- Mibrasa Ecofire firelighters [FL]

OPTIONAL ACCESSORIES

- V-shape grill [GV200]
- Swivel hook [GGCV]
- Extra rod grill [CPV200]
- Thermal protector [EPGMB200]
- End of service lid [TAPAGMB200]
- Espeto skewer kit [KITESPGMB200]
- Vertical cooking rack [CPH-200]
- GN support kit [SGN200]

Specifications and design are subject to change without notice.

QUALITY GUARANTEE





Parrilla GMB 200

FRONT VIEW

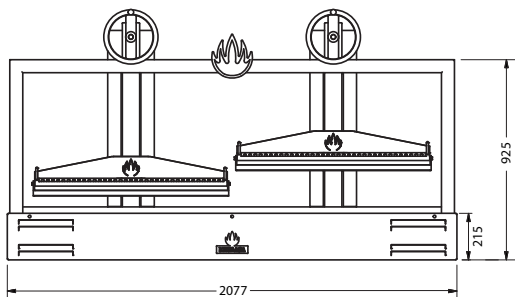

SIDE VIEW

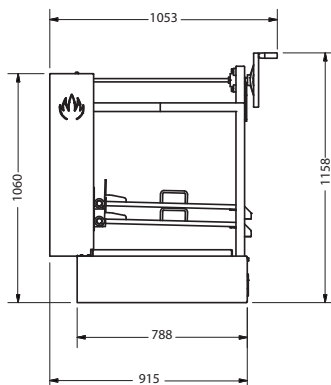

TOP VIEW

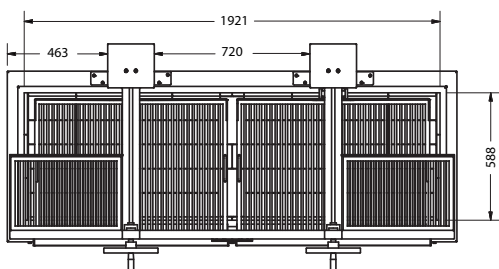

Dimensions in mm

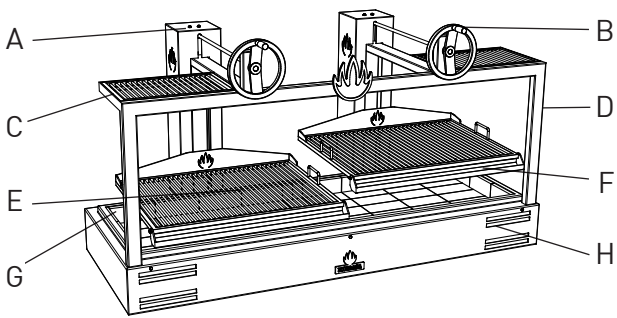

A	Reverse elevating system
B	Elevating wheel
C	Heating rack
D	Structure
E	Grill
F	Grease collector
G	Refractory bricks
H	Main body

GRILL TYPES

Rod bar grill

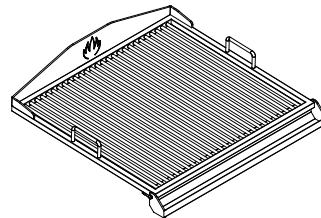

V-shape grill

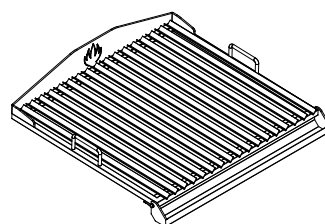

GRILL DIMENSIONS

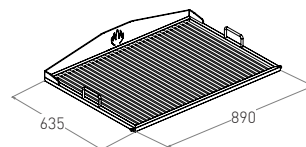

HEATING RACK DIMENSIONS

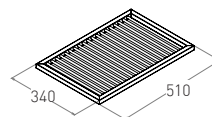

Revit drawings available on request at mibrasa@mibrasa.com

INSTALLATION GUIDELINES AND SAFETY STANDARDS

Recommended installation height	700 mm
Clearances to construction/other appliances from the Parrilla	76 mm
Clearances of flammable materials from the Parrilla	300 mm
Clearance of workspace from front of the Parrilla	700 mm



*It is recommended to use a lifting device to lift the Parrilla and place on the countertop/stand.

Consult Parrilla instruction manual for further information.

Specifications and design are subject to change without notice.



Parrilla GMB 200

OPTIONAL COMPLETE STAND



TECHNICAL INFORMATION

Ref.	GMB200 + MCGMB200
Net weight ³	588 kg
Crated weight* ³	758 kg
Crated size (WxDxH)	1120 x 2200 x 2000

Ref.	MCGMB200
Net weight ³	125 kg
Crated weight* ³	145 kg
Crated size (WxDxH)	1120 x 2200 x 700
No. drawers	3
No. GN rack slots	5

OPTIONAL ACCESSORIES

- S/S Casters [WINOX]

FRONT VIEW

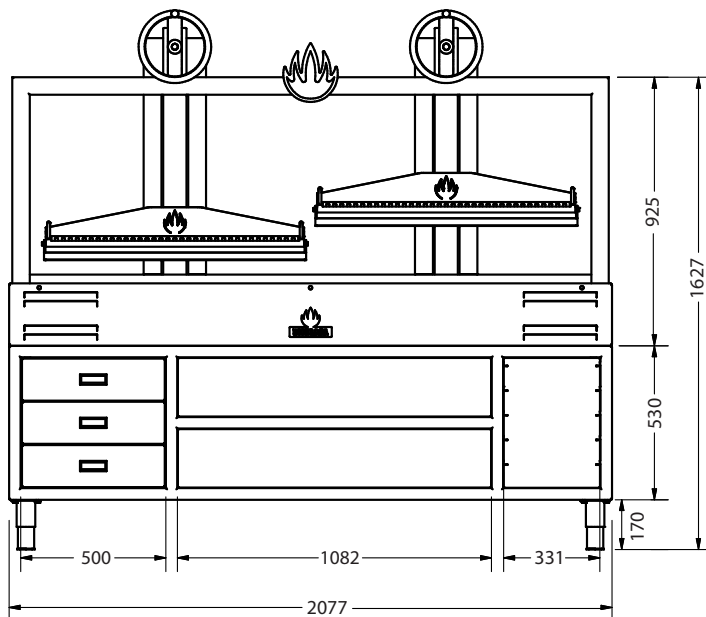

SIDE VIEW

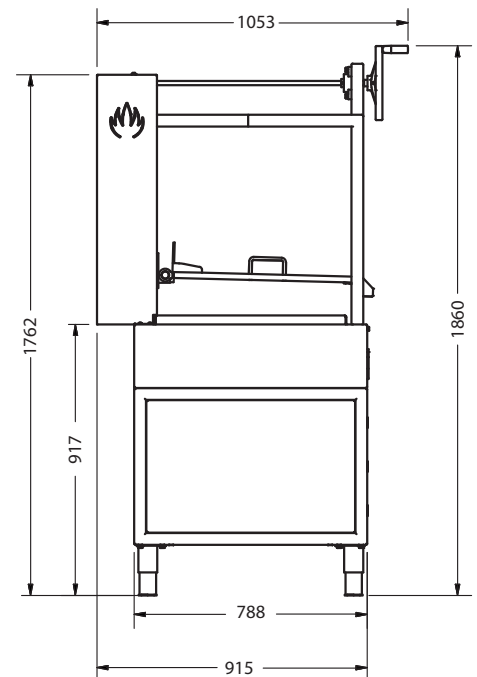

Dimensions in mm

Specifications and design are subject to change without notice.



Parrilla GMB 200

OPTIONAL STAND



TECHNICAL INFORMATION

Ref.	GMB200 + MGMB200
Net weight ³	510 kg
Crated weight* ³	680 kg
Crated size (WxDxH)	1120 x 2200 x 2000

Ref.	MGMB200
Net weight ³	47 kg
Crated weight* ³	67 kg
Crated size (WxDxH)	1120 x 2200 x 700

OPTIONAL ACCESSORIES

- S/S Casters [WINOX]
- Gastronorm rack [SGN200]

FRONT VIEW

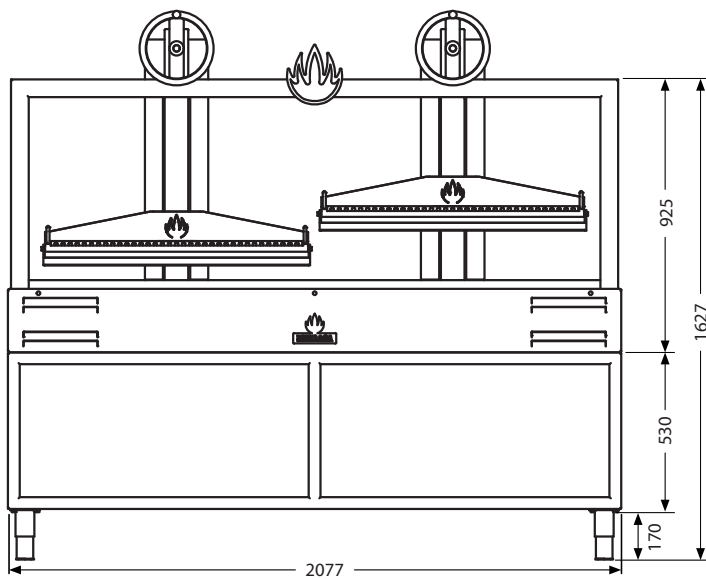

SIDE VIEW

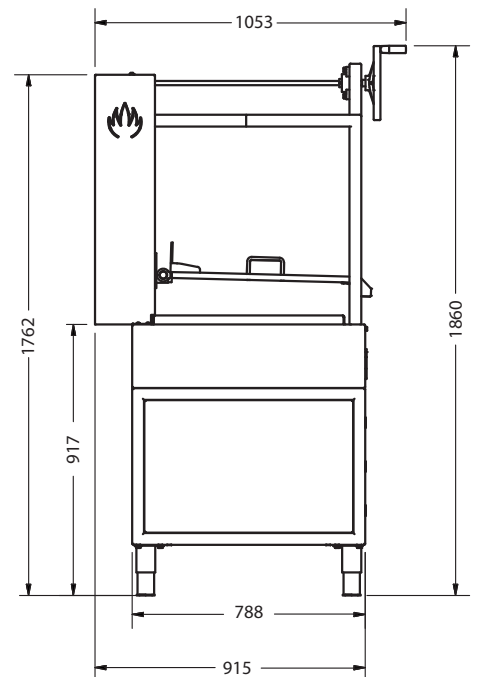

Dimensions in mm

Specifications and design are subject to change without notice.